

HARD-BITE™ – HP-77750-B

Dimensions

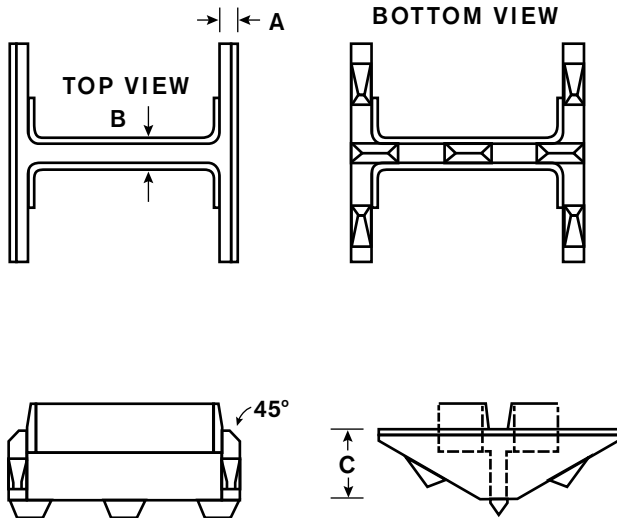

MATERIAL: CAST STEEL

ASTM A148 90/60

	10"	12"	14"
A	3/4"	3/4"	1"
B	1-3/8"	1-1/2"	1-5/8"
C	3"	3-1/2"	4"
Wt.	19#	25#	42#

NORMAL FOUNDRY TOLERANCES APPLY

Installation Instructions

1. Fit point onto the end of the square cut pile end.
2. Weld point to the pile in either flat or vertical position using E70XX electrodes or equivalent filler material.
3. Weld across full width of flange following chart below for minimum size weld.

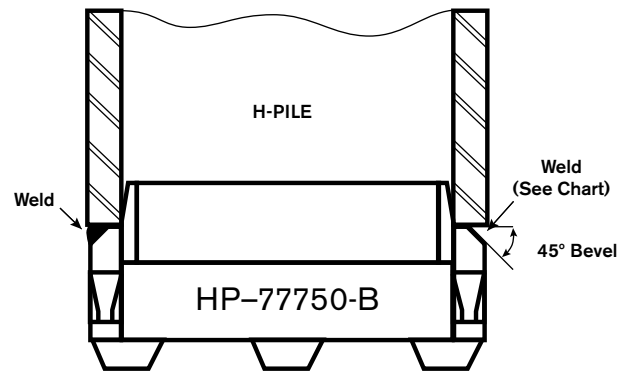

Pile Size	Flange Thickness	Groove Weld
HP 14 x 117	.805	7/16
x 102	.705	3/8
x 89	.615	3/8
x 73	.505	5/16
HP 12 x 102	.820	3/8
x 84	.685	3/8
x 74	.610	3/8
x 63	.515	5/16
x 53	.435	5/16
HP 10 x 57	.565	5/16
x 42	.420	5/16



**ASSOCIATED PILE
& FITTING**

45 Samworth Road, Clifton, NJ 07014

Tel: 973-773-8400

Fax: 973-773-8442

email: apf@associatedpile.com

www.associatedpile.com

Call Toll Free: 800-526-9047